

This drawing is for information only and must not be used for construction or fabrication, prior to final design.

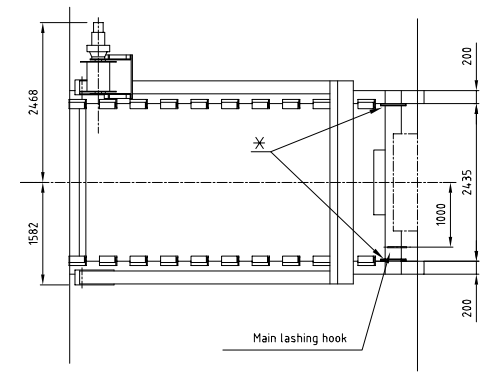

View P

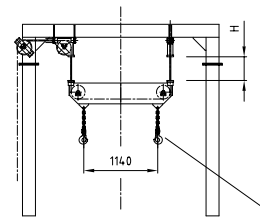

Chains to be shortened on assembly
minimum value for "H" = 100mm
in lifting position

CONTROL HANDLES

View Q

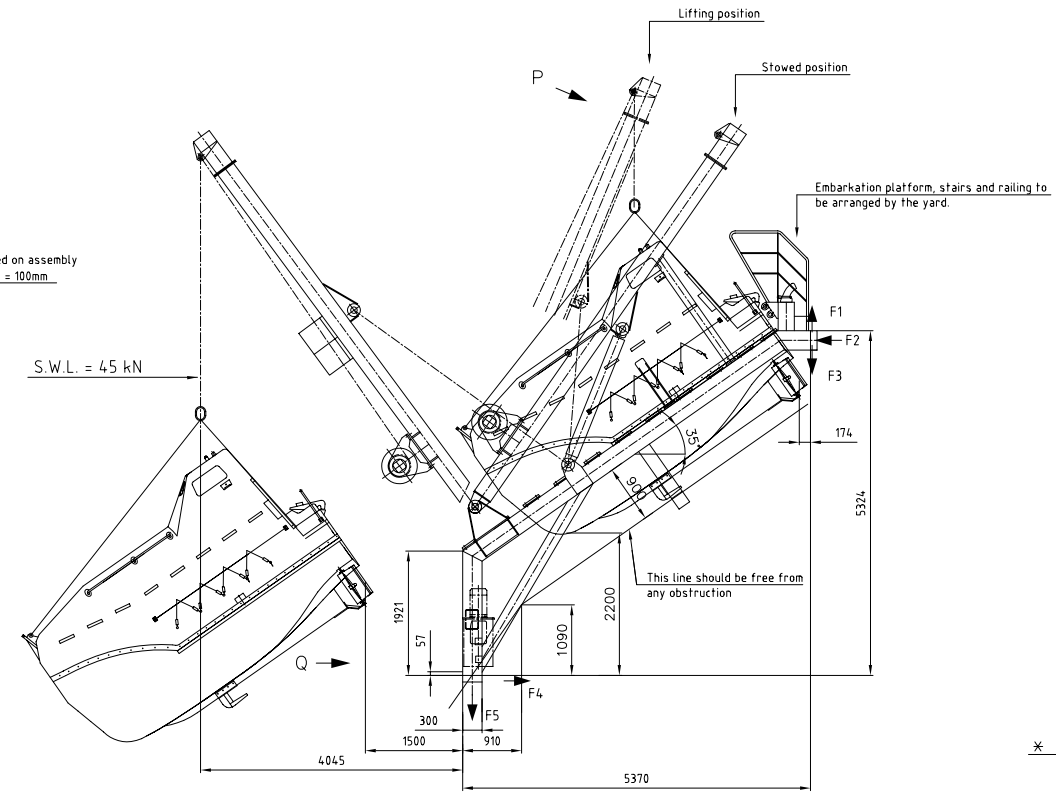
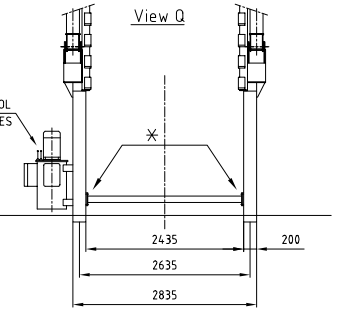

SPECIFICATIONS	
MANUFACTURER DAVIT	NED-DECK MARINE
S.W.L.	4500 KG
TYPE	FFH-45
MANUFACTURER BOAT	N.M.E.
BOAT WEIGHT incl.FUEL,EQUIPMENT	2175 KG
NUMBER OF PERSONS	19
TYPE OF BOAT	JY-FN-4,9

ITEM	WEIGHT
DAVIT WITH WINCH	5480 KG
HYDR.POWER PACK	175 KG
OIL TOTAL	85 KG
WEIGHT TOTAL WET APPROX.	5740 KG

F1	20 kN
F2	20 kN
F3	40 kN
F4	20 kN
F5	70 kN

a) All forces are "action" forces.
b) Forces shown are per beam.
c) Forces are based on S.W.L. plus 10% overload.

FOR SCOPE OF SUPPLY SEE ORDER

Sheaves and pivot points contain self-lubricated bushes which have to be greased prior to assembly

Davit will be delivered with 100mm overlength and must be cut on correct length by yard to suit deck

All separate delivered parts to be welded or mounted by yard

* Connection flanges after mounting to be welded together by yard

		NED-DECK MARINE Survival Systems & Deck Equipment		DRAWN: RJB DATE: 28.04-'04 APPROVED:	TOLERANCES NEN-ISO 2768-1
15 1244 Upgrade SP 16 1244 Upgrade SP 17 1244 Upgrade SP 18 1244 Upgrade SP 19 1244 Upgrade SP 20 1244 Upgrade SP 21 1244 Upgrade SP 22 1244 Upgrade SP 23 1244 Upgrade SP 24 1244 Upgrade SP 25 1244 Upgrade SP 26 1244 Upgrade SP 27 1244 Upgrade SP 28 1244 Upgrade SP 29 1244 Upgrade SP 30 1244 Upgrade SP 31 1244 Upgrade SP 32 1244 Upgrade SP 33 1244 Upgrade SP 34 1244 Upgrade SP 35 1244 Upgrade SP 36 1244 Upgrade SP 37 1244 Upgrade SP 38 1244 Upgrade SP 39 1244 Upgrade SP 40 1244 Upgrade SP 41 1244 Upgrade SP 42 1244 Upgrade SP 43 1244 Upgrade SP 44 1244 Upgrade SP 45 1244 Upgrade SP 46 1244 Upgrade SP 47 1244 Upgrade SP 48 1244 Upgrade SP 49 1244 Upgrade SP 50 1244 Upgrade SP 51 1244 Upgrade SP 52 1244 Upgrade SP 53 1244 Upgrade SP 54 1244 Upgrade SP 55 1244 Upgrade SP 56 1244 Upgrade SP 57 1244 Upgrade SP 58 1244 Upgrade SP 59 1244 Upgrade SP 60 1244 Upgrade SP 61 1244 Upgrade SP 62 1244 Upgrade SP 63 1244 Upgrade SP 64 1244 Upgrade SP 65 1244 Upgrade SP 66 1244 Upgrade SP 67 1244 Upgrade SP 68 1244 Upgrade SP 69 1244 Upgrade SP 70 1244 Upgrade SP 71 1244 Upgrade SP 72 1244 Upgrade SP 73 1244 Upgrade SP 74 1244 Upgrade SP 75 1244 Upgrade SP 76 1244 Upgrade SP 77 1244 Upgrade SP 78 1244 Upgrade SP 79 1244 Upgrade SP 80 1244 Upgrade SP 81 1244 Upgrade SP 82 1244 Upgrade SP 83 1244 Upgrade SP 84 1244 Upgrade SP 85 1244 Upgrade SP 86 1244 Upgrade SP 87 1244 Upgrade SP 88 1244 Upgrade SP 89 1244 Upgrade SP 90 1244 Upgrade SP 91 1244 Upgrade SP 92 1244 Upgrade SP 93 1244 Upgrade SP 94 1244 Upgrade SP 95 1244 Upgrade SP 96 1244 Upgrade SP 97 1244 Upgrade SP 98 1244 Upgrade SP 99 1244 Upgrade SP 100 1244 Upgrade SP	Description:	TITLE: FREE FALL DAVIT "FFH 45"	SCALE: 1:40 DRAWING NUMBER: P-101868	PROJECTOR:	SIZE: A1 REVISION: D